

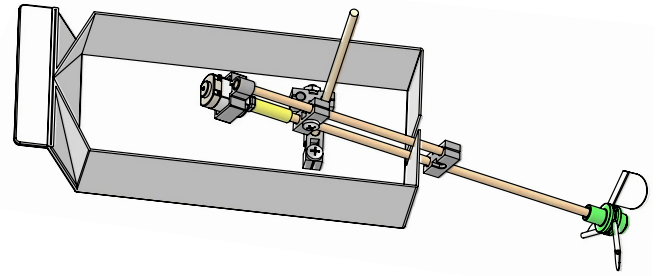





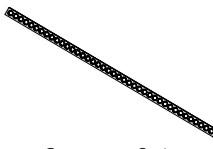
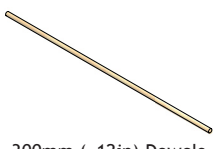

## The Activity

This guide will take you through the process of creating a boat; motor, custom propeller, and hull.

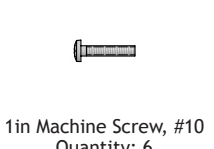

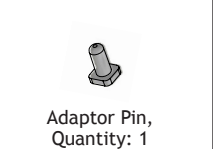
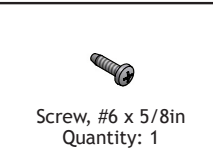
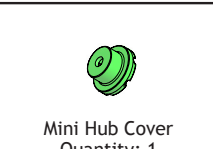
## What Will You Need?

Materials included in the kit:

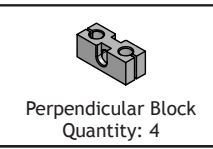
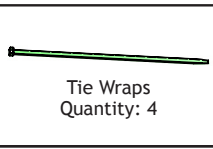
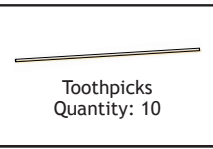



 Connector Strip Quantity: 4	 300mm (~12in) Dowels Quantity: 6	 100mm (3in) Slide Stop Quantity: 1	 1in Machine Screw, #10 Quantity: 6	 Nut, #10 Quantity: 4	 Adaptor Pin, Quantity: 1
 Screw, #6 x 5/8in Quantity: 1	 Mini Hub Cover Quantity: 1	 Mini Hub Spline Base Quantity: 1	 1.5V Mini Motor Quantity: 1	 Mini Motor Mount Quantity: 1	 AA Battery Holder Quantity: 1
 Perpendicular Block Quantity: 4	 Tie Wraps Quantity: 4	 Toothpicks Quantity: 10			

### Required Materials, Not Included:

- 1 AA Battery
- Beverage containers (milk, juice), foam trays, foam sheets,
- Pipe foam, etc. (to create the boat hull).
- Duct tape to build the propeller

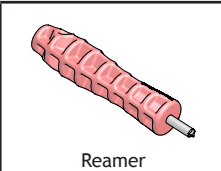

### Tools to build a boat:

 Cutter	 Reamer	 Optional: Wax, Soap or Crayon	 Optional: Hammer	 Optional: Pliers
---	---	---	--	---

Built it, test it, change it. TeacherGeek™ components allow you to design and engineer your most imaginative mechanisms. Combine them with other materials and products. More resources are available at [teachergeek.com](http://teachergeek.com).

### Dowels

Dowels vary in diameter. Some may be too large or small to use.

The ends of dowels may taper and need to be cut off to fit tightly into holes.

### Cutting

Dowels and Connector Strips can be cut with a multi-cutter (best method), saw, side cutters or pruning shears. Wear safety glasses when cutting.



Multi-Cutters

## Holes & Reaming

Components come with holes that dowels press securely into.

Reaming holes to allow dowels to rotate and slide freely.



Turn a reamer back and forth through a hole.

## Push, Wiggle, Tap

Push dowels into holes by:

1. Wiggling and pressing with your hands
2. Tapping dowels with a hammer or the side of your cutter.

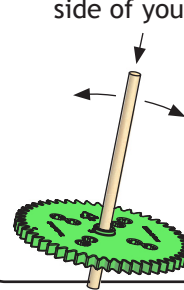

Tip: Rub a dowel with soap, wax or a crayon to allow it to slide easier into and out of holes.

## Start Building!!!



**WARNING!!!** Most holes should not be reamed. Do not ream holes which dowels should stay pressed into.

### Step #1

- A) Cut a 150mm (6in) dowel.
- B) Slide two perpendicular blocks onto the dowel, to the measurement shown below. Make sure the blocks are parallel.

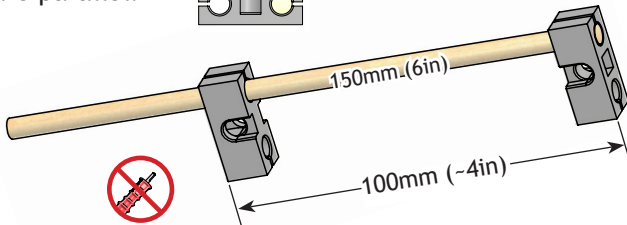

### Step #2

Ream the holes marked with a ⊕.

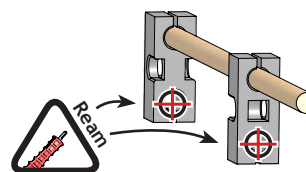

### Step #3

If your adaptor pins came connected, cut them apart.

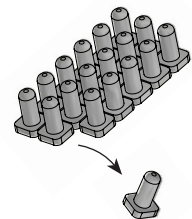

### Step #4

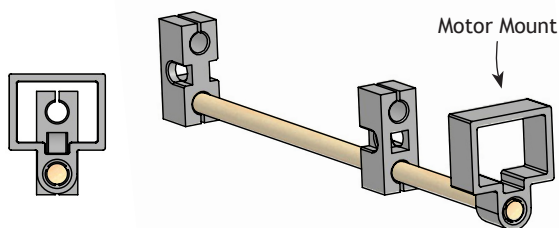

Attach the motor mount. Make sure it is parallel with the perpendicular blocks.

### Step #5

Place the adaptor pin onto the motor shaft.

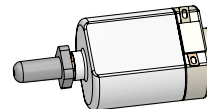

#### Tip

Push the adaptor pin into a perpendicular block.

2. Tap the motor shaft into the adaptor pin.

3. Remove the perpendicular block.

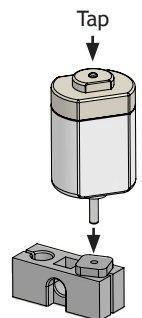

### Step #6

Place a 25mm (1in) section of slide stop onto the adaptor pin.

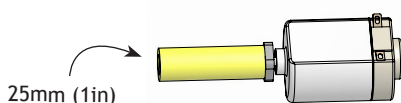

### Step #7

Insert the motor into the mount.

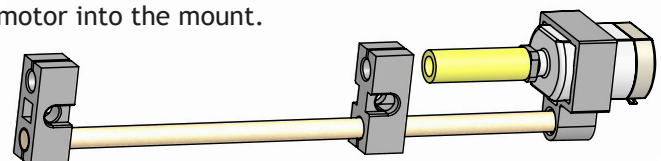



The boat to the left is called a “long tail” because of the long straight motor shaft. Do you think it looks like the motor you are building?

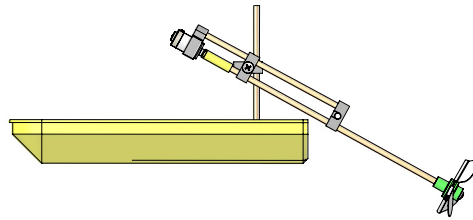

## Step #8

Insert an uncut (300mm, ~12in) dowel into the mini hub base.



## Step #9

Attach the mini hub cover to the base using a #6 screw. Be careful not to over-tighten the screw.

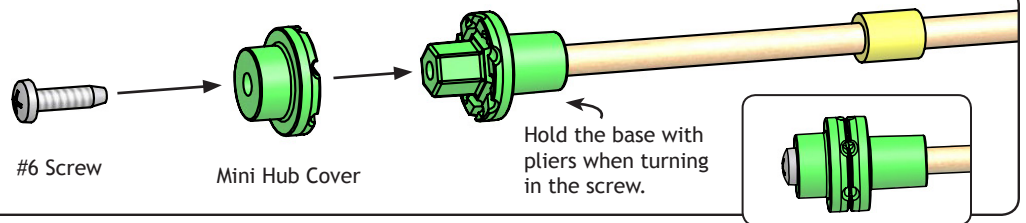

## Step #10

Insert the hub assembly from Step #7 into the motor assembly from step #8.

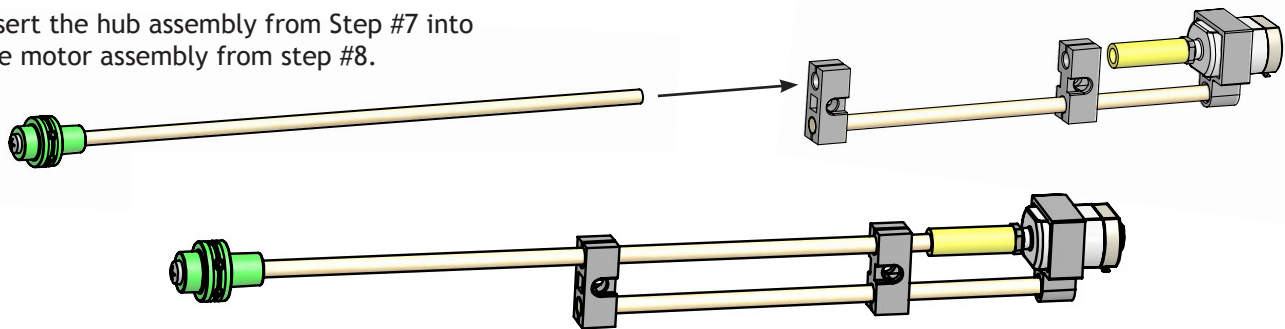

## Step #11

Attach a perpendicular block using a machine screw and nut.

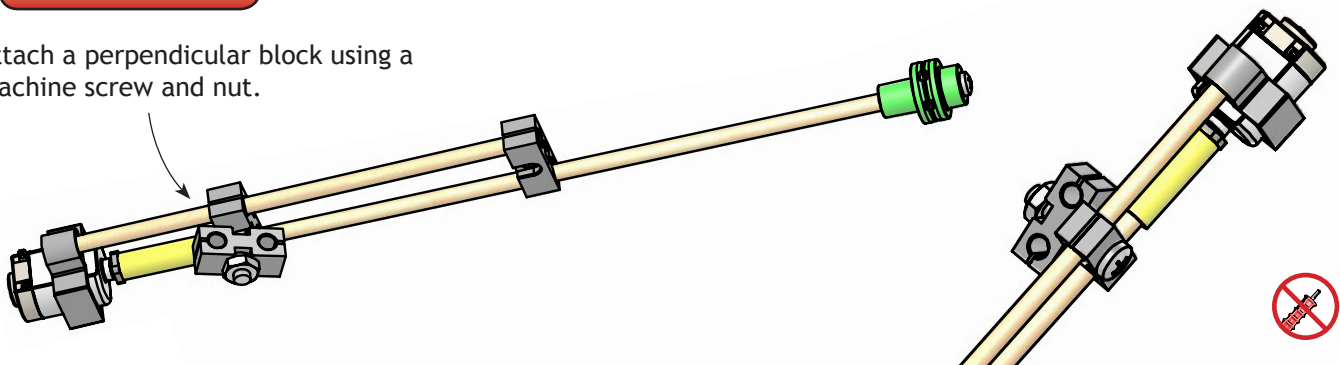

## Step #12

It's time to design and build your motor mount and boat hull. Here are some example configurations. You supply the materials for the boat hull.

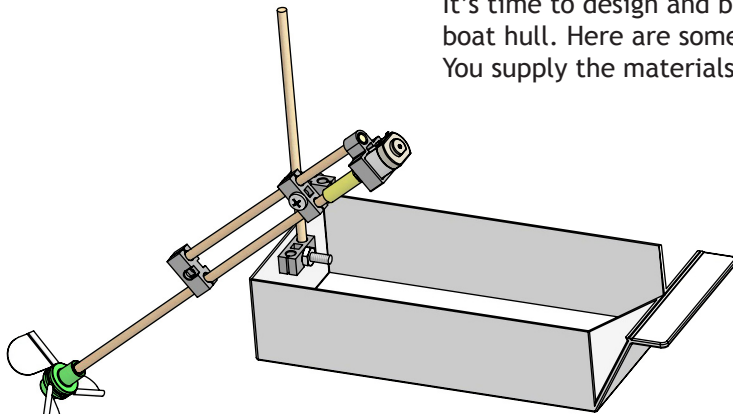

The propeller will be created later.

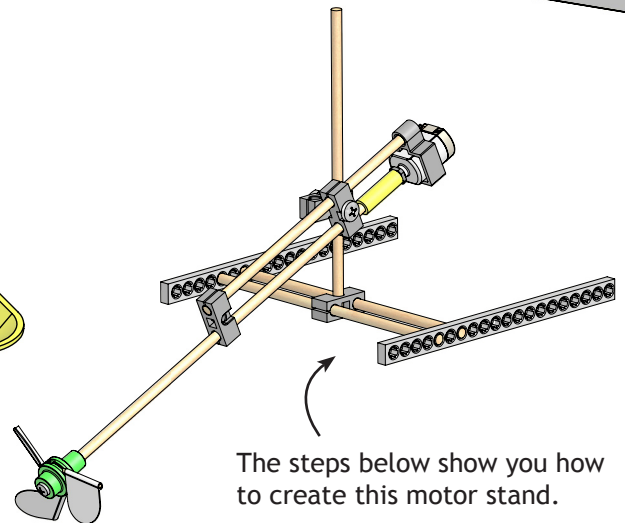
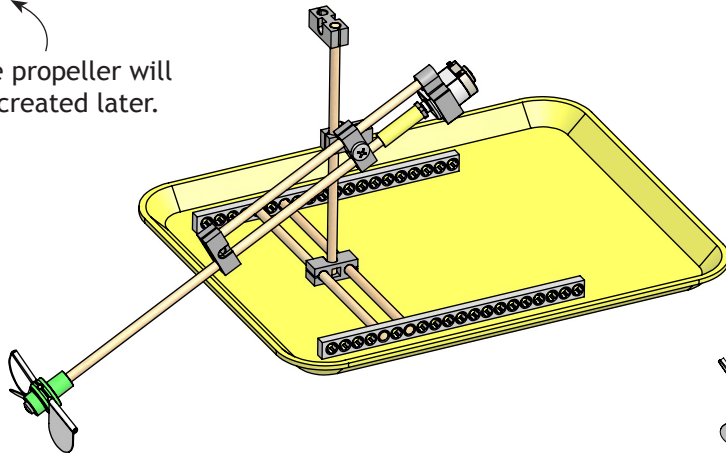
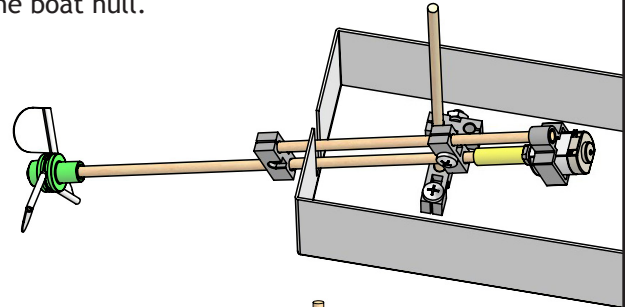

The steps below show you how to create this motor stand.

## Step #13

Cut two 150mm (6in) dowels. Push a perpendicular block to the middle of the two dowels.

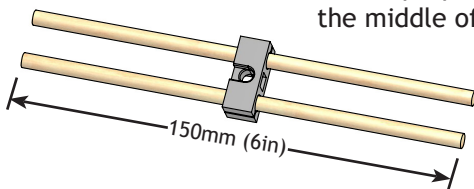

## Step #14

Place a 150mm (6in), or longer, dowel into hole  in the perpendicular block.

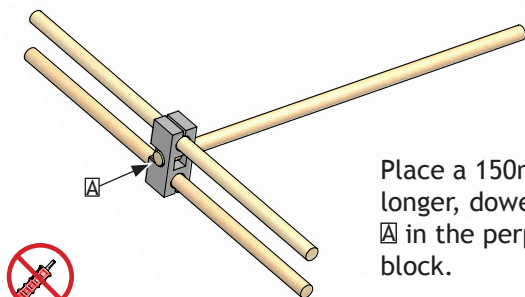

## Step #15

Cut two 150mm (6in) connector strips. Attach them to the assembly from Step #14 as shown.

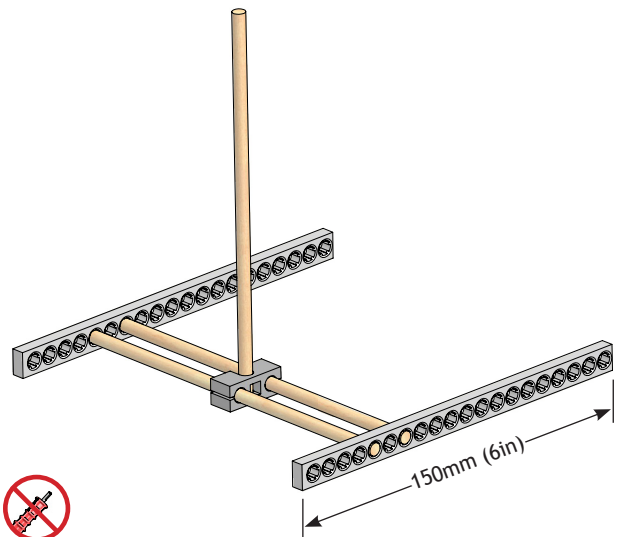

## Step #16

Cable ties are included to help you attach your battery holder (where you choose to attach it).

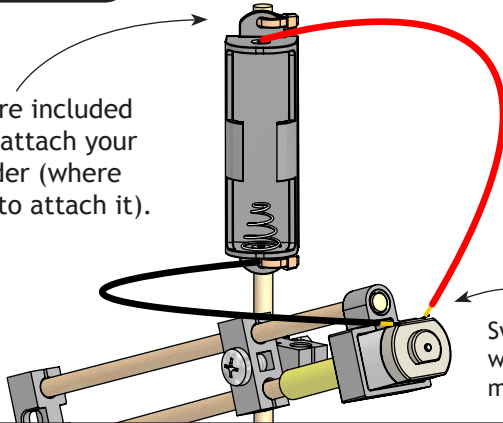

A) Attach the battery holder to your boat.

- B) Run battery holder wires to your motor terminals. The motor can be turned on and off by:
1. removing the battery
  2. removing a wire from a motor terminal.

Swapping wires will reverse the motor direction.

Motor Terminals

Wrap the wire around the motor terminal.

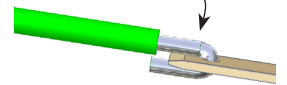
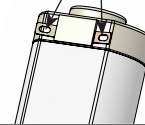

## Propeller Build

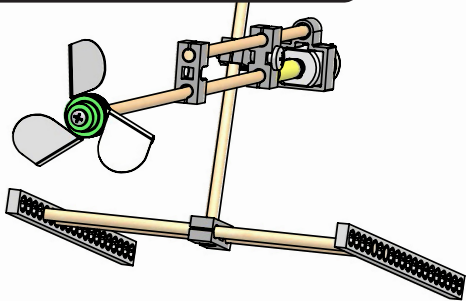

## Step #17

Cut the grooved and pointed ends off the toothpicks.

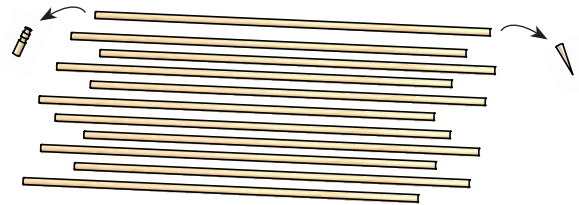

## Step #18

Cut three 100mm (3in) sections of tape (preferably duct tape) and lay them, sticky side up, on top of each other.

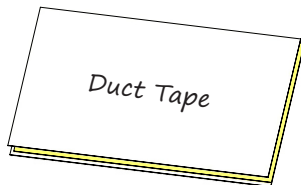

## Step #19

Place a toothpick in the middle of the layered tape. The toothpick should overhang the tape by at least 15mm (.6in).

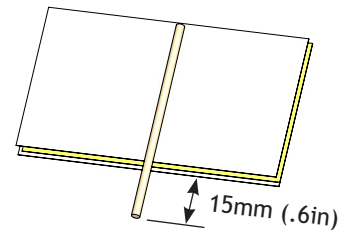

## Step #20

Fold over the tape from Step #13.

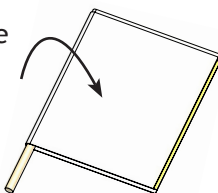

## Step #21

Cut the blade to the desired shape.

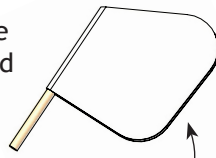

This is not the best shape (try your own).

## Step #22

A) Loosen the screw 1/4 turn.

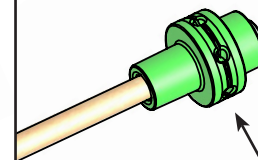

B) Place blades into the hub.

c) Tighten the screw

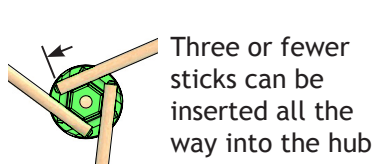
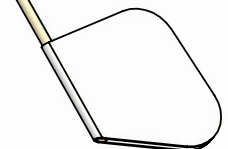

Three or fewer sticks can be inserted all the way into the hub

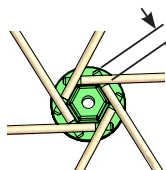

Six Skewer sticks can be inserted in a hub, but they must be held back as shown.

## Step #23

It is now time for you to experiment with different blade configurations. You will be able to change the shape of your blades, the number of blades used (between 1 and 6), and the blade angle.

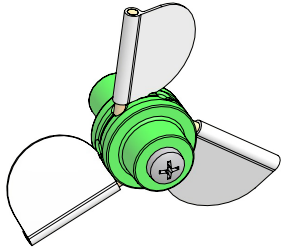

Blade pitch can be changed when the hub screw is loose.

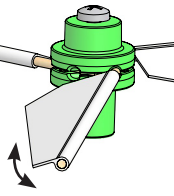

## Step #24

Does your boat need a rudder?



## Extreme Challenges

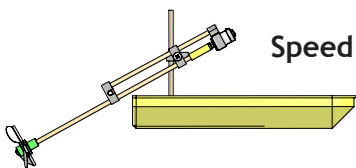

Speed

It's time to further develop your boat. Engineer it for one competition, change it for another. No design is ever perfect. Experimentation is important. Don't stop innovating.

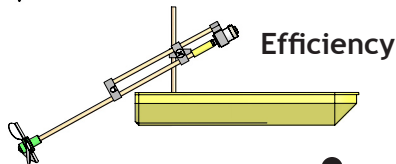

Efficiency



$$\frac{\text{Mass Carried}}{\text{Time of Travel}}$$

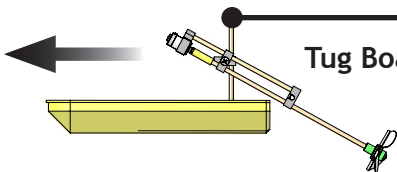

Tug Boats

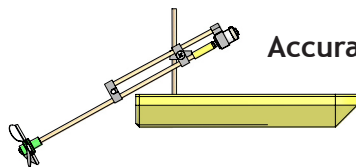

Accuracy

Which boat makes it to the target, or the end of the pool first?



Personalize your boat.  
Give it looks and character.

## Guide

Boats can use a guide line to keep them straight in large pools.

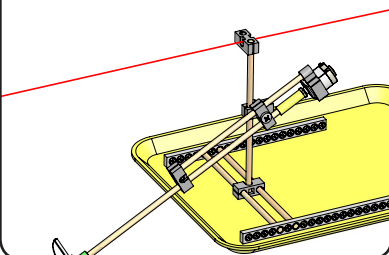

## Track

Gutters and cut pipes make great boat tracks.

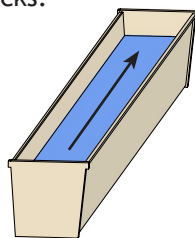

## Innovate!!!

Create your own innovative boat design. Could it be an air boat?

